

DIN 126 Specifications

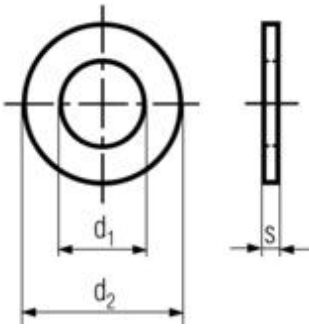

All measurements in millimeters (mm)

d_1	used for	d_2	s
5.5	M5	10	1
6.6	M6	12	1.6
7.6	M7	14	1.6
9	M8	16	1.6
11	M10	20	2
13.5	M12	24	2.5
15.5	M14	28	2.5
17.5	M16	30	3
22	M20	37	3
26	M24	44	4
30	M27	50	4
33	M30	56	4
36	M33	60	5
39	M36	66	5
42	M39	72	6
45	M42	78	7
48	M45	85	7
52	M48	92	8
56	M52	98	8
62	M56	105	9
66	M60	110	9
70	M64	115	9

All information is strictly informative