

DIN 127 Specifications

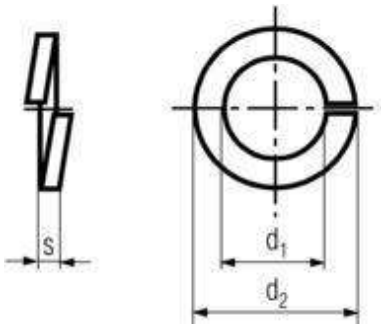

All measurements in millimeters (mm)

d₁	for screw size	d₂	s
2.1	M2	4.4	0.5
2.6	M2.5	5.1	0.6
3.1	M3	6.2	0.8
3.6	M3.5	6.7	0.8
4.1	M4	7.6	.09
5.1	M5	9.2	1.2
6.1	M6	11.8	1.6
8.1	M8	14.8	2
10.2	M10	18.1	2.2
12.2	M12	21.1	2.5
14.2	M14	24.1	3
16.2	M16	27.4	3.5
18.2	M18	29.4	3.5
20.2	M20	33.6	4
22.5	M22	35.9	4
24.5	M24	40	5
27.5	M27	43	5
30.5	M30	48.2	6
33.5	M33	55.2	6
36.5	M36	58.2	6
39	M38	61.2	6
42.5	M42	68.2	7
45.5	M45	71.2	7
49	M48	75	7
53	M52	86	8

All information is strictly informative