

DIN 128 Specifications

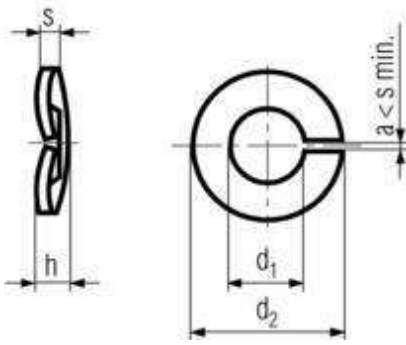

All measurements in millimeters (mm)

d₁	for screw size	d₂	s	h min	h max
2.1	M2	4.4	0.5	0.7	0.9
2.6	M2.5	5.1	0.6	0.9	1.1
3.1	M3	6.2	0.7	1.1	1.3
3.6	M3.5	6.7	0.7	1.1	1.3
4.1	M4	7.6	0.8	1.2	1.4
5.1	M5	9.2	1	1.5	1.7
6.1	M6	11.8	1.3	2	2.2
8.1	M8	14.8	1.6	2.45	2.75
10.2	M10	18.1	1.8	2.85	3.15
12.2	M12	21.1	2.1	3.35	3.65
14.2	M14	24.1	2.4	3.9	4.3
16.2	M16	27.4	2.8	4.5	5.1
18.2	M17	29.4	2.8	4.5	5.1
20.2	M20	33.6	3.2	5.1	5.9
22.2	M21	35.9	3.2	5.1	5.9
24.5	M24	40	4	6.5	7.5
30.5	M30	48.2	6	9.5	10.5

All information is strictly informative