

DIN 7980 Specifications

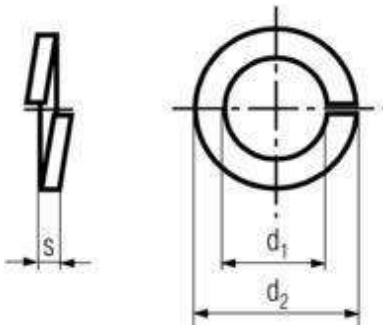

All measurements in millimeters (mm)

d₁	used for	s	d₂
3.1	M3	1	5.6
4.1	M4	1.2	7
5.1	M5	1.6	8.8
6.1	M6	1.6	9.9
8.1	M8	2	12.7
10.2	M10	2.5	16
12.2	M12	2.5	18
14.2	M14	3	21.1
16.2	M16	3.5	24.4
18.2	M18	3.5	26.4
20.2	M20	4.5	30.6
22.5	M22	4.5	32.9
24.5	M24	5	35.9
27.5	M27	5	38.9
30.5	M30	6	44.1
33.5	M33	6	47.1
36.5	M36	7	52.2

All information is strictly informative